

Air Scale System

The Highest Quality Air Scale System For On-Board Weighing Applications



The SI Onboard Airscale system provides gross or net vehicle weight by monitoring air pressure from your air suspension and converting this to a weight.

This information is used in avoiding overload fines, choosing disposal sites, and reducing truck maintenance. The system can be installed on any truck with an air suspension. Axle group weights are provided, as well as gross and net weights. Rear-axle-group-only and front-axle-group-only systems are also available.

Key Features:

- Up to 2% of net payload
- Gross/Net weight displayed with no driver interaction
- Axle group weight displayed with no driver interaction
- Easy to operate - One program
- Extensive self diagnostic
- Easy two-step calibration
- Post calibration
- Weight set-alarm points

Options:

- Printer
- Relay board
- Hand held remote



**Air Scale System
9101310**

Applications:

- Forestry/logging
- Waste
- Bulk hauling
- Aggregate
- Dump truck
- Roll offs
- Agriculture
- Tow trucks

5920 South 194th Street | Kent, WA 98032 | USA
Sales Support: 800-638-5111 | Technical Support: 626-202-5047
E-mail: Obw.usa@vpgsensors.com

sionboard.com



Air Scale System - 9101310

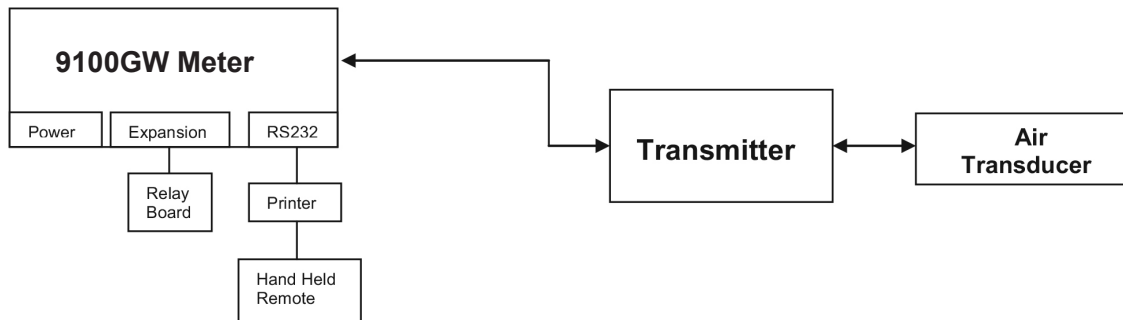

- * Complete Truck system shown
- * Available kits for dual leveling valves

PARAMETERS	MIN	TYPE	MAX	UNIT
Acuracy	0.5%	1.0%	2.0%	Full Scale
Number of Transducers		1 or 2		
Number of Channels		1 or 2		
METER				
Display Digits	45" high, 7-segment, 6-digit, bright-red LED			
Size	6.5" L X 3.2" W X 2.3" D; 2.1 LBS			
Divisions	20, 50, 100 (pounds or KG)			
Units				
Operating Voltage	11.5		16	VDC
Current Consumption			400	mA
Operating Temperature	14		104	°F
Conversion (Frequency to digital)		2		updates/second
Resolution		4000		
Communications		RS232		
TRANSMITTERS				
Analog Input	0.4		1.0	mVN
Conversions Ratio		66		kHz/mV
TRANSDUCER				
Material	Aluminum Alloy			
Size	4" + 2' Cable			
Output (@ 150 PSIG)	0.5	1	1.5	mVN
Impedance	350 Ω Min			Ohm
Capacity			150	PSI

DISCLAIMER: ALL PRODUCTS, PRODUCT SPECIFICATIONS AND DATA ARE SUBJECT TO CHANGE WITHOUT NOTICE. Vishay Precision Group, Inc., its affiliates, agents, and employees, and all persons acting on its or their behalf (collectively, "VPG"), disclaim any and all liability for any errors, inaccuracies or incompleteness contained herein or in any other disclosure relating to any product. The product specifications do not expand or otherwise modify VPG's terms and conditions of purchase, including but not limited to, the warranty expressed therein. VPG makes no warranty, representation or guarantee other than as set forth in the terms and conditions of purchase. **To the maximum extent permitted by applicable law, VPG disclaims (i) any and all liability arising out of the application or use of any product, (ii) any and all liability, including without limitation special, consequential or incidental damages, and (iii) any and all implied warranties, including warranties of fitness for particular purpose, non-infringement and merchantability.** Information provided in datasheets and/or specifications may vary from actual results in different applications and performance may vary over time. Statements regarding the suitability of products for certain types of applications are based on VPG's knowledge of typical requirements that are often placed on VPG products. It is the customer's responsibility to validate that a particular product with the properties described in the product specification is suitable for use in a particular application. You should ensure you have the current version of the relevant information by contacting VPG prior to performing installation or use of the product, such as on our website at vpgsensors.com. No license, express, implied, or otherwise, to any intellectual property rights is granted by this document, or by any conduct of VPG. The products shown herein are not designed for use in life-saving or life-sustaining applications unless otherwise expressly indicated. Customers using or selling VPG products not expressly indicated for use in such applications do so entirely at their own risk and agree to fully indemnify VPG for any damages arising or resulting from such use or sale. Please contact authorized VPG personnel to obtain written terms and conditions regarding products designed for such applications. Product names and markings noted herein may be trademarks of their respective owners.