



Aircraft Weighing System

Model Evergreen Weigh Road Runner with Full Function Indicator EW 9150

Technical/Operator Manual



Revere/Evergreen Weigh
Vishay Precision Group

Technical Support: (253) 872-1910

PN: 6190240 Rev. C

TABLE OF CONTENTS

Disclaimer	3
Precautions/Warnings	4
Introduction	5
Component Description	6
Load Cells	7
Load Cell Adapters	7
Load Cell Kits	8
Load Cell Kits Available	9
System Specifications	10
Setup/Pre-operation	11
Pre-operational Procedures	11
Jack Point Configuration	11
Preparation For Aircraft Weighing	12
Control Panel Setup	13
Quick Setup Steps	21
Operation	22
Aircraft Weighing Cycle	23
Zeroing	23
Lifting	23
Weighing	23
Removing	24
Reporting	24
Printer Format	25
Troubleshooting	26
Weight Input Errors	26
General Command/Communications Errors	27
Hardware Errors	27
Maintenance	28
Warranty	29
Appendix	30
Dummy Plug	30

DISCLAIMER

Revere/Evergreen Weigh makes no representation or warranties of any kind with respect to the contents hereof and specifically disclaims any implied warranties or merchantability or fitness for any particular purpose. Revere/Evergreen Weigh shall not be held liable for errors contained herein or for incidental or consequential damages in connection with the furnishing, performance or use of this publication or its contents. Revere/Evergreen Weigh reserves the right to revise this manual at any time and to make changes to the contents herein without obligation to notify any person of such revision or changes.



WEEE Waste Electrical and Electronic Equipment. This symbol on the product or on its packaging indicates that this product must not be discarded or disposed with regular waste. It is the users responsibility to dispose of waste equipment according to local laws. The separate collection and recycling of the waste equipment at the time of disposal will help to conserve natural resources and ensure that it is recycled in a manner that protects human health and the environment.

PRECAUTIONS

READ this manual BEFORE operation or servicing this equipment.

FOLLOW these instructions carefully:.



WARNINGS

Only permit qualified personnel to install and service this instrument.

Exercise care when making checks, tests, and adjustments that must be made with power on.

Failing to observe these precautions can result in bodily harm.

DO NOT allow untrained personnel to operate, clean, inspect, maintain, service, or tamper with this equipment.

DO NOT expose connectors (or equipment in operation) to water, grease or other conductive material that may cause shorting of the channel excitation voltage. This could lead to permanent equipment damage.

Use earth ground power socket ONLY.

DO NOT close lid when in operation.

Maintain clearance around the power connector for easy operation.

IF equipment is used other than the method written in this manual, then protection provided by the equipment may be impaired.

FLAMMABLE LIQUIDS must be handled with CARE.

ALL applicable local procedures and precautions shall be followed when using any aircraft weighing system and/or components in and around fueling stations or when using the components within the accessory kit to obtain fuel samples.

(SAVE this manual for future reference.)

INTRODUCTION

The Revere/Evergreen Weigh Aircraft Weighing System, Model EW 9150, integrates state of the art communication, digital weight processing and high accuracy hermetically sealed load cells. A force transducer (Load Cell) produces a signal proportional to the force applied to it. This signal is transmitted through channel specific, color coded cables to the EW 9150 where the measurement is processed. Analog load cell signals are processed digitally to remove linearity errors, latitude and altitude effects. Presentation in pounds or kilograms is selectable by the operator. An RS-232 printer port provides a permanent record of all pertinent weighing information including deviations that are accepted by the operator. Gravity corrections are applied based on customer site parameters of latitude and elevation. The EW 9150 Controller/Display features a graphical color touch screen with intuitive step-by-step operation.



Controller Display



Platform



Jack Point Load Cells



EW 9150 Aircraft Weighing System

COMPONENT DESCRIPTION

EW 9150 Controller/Display

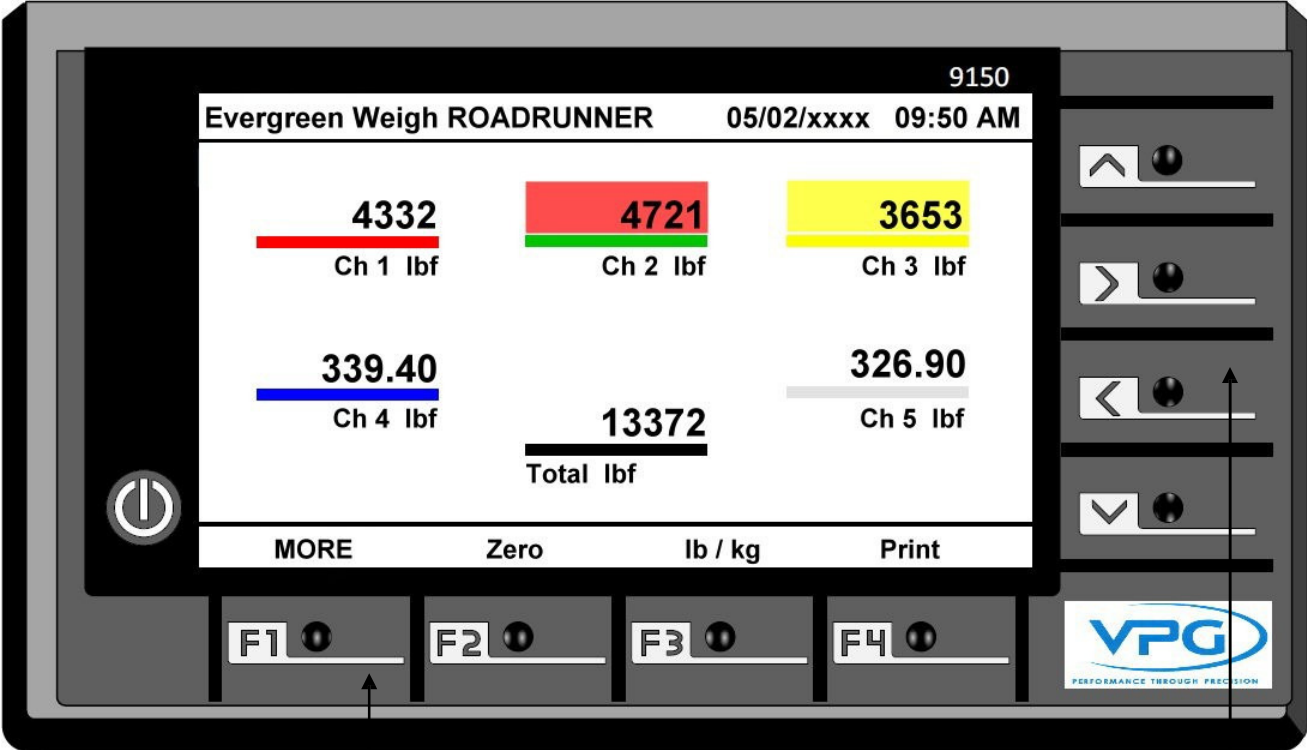

Function Select Buttons. Function is indicated on the display and selected by the button immediately below.

Screen Movement Buttons



Cable Receptacles for Load Cells

- Power Connector
- RS-232 Printer Port

COMPONENT DESCRIPTION

Force Transducers (Load Cells)

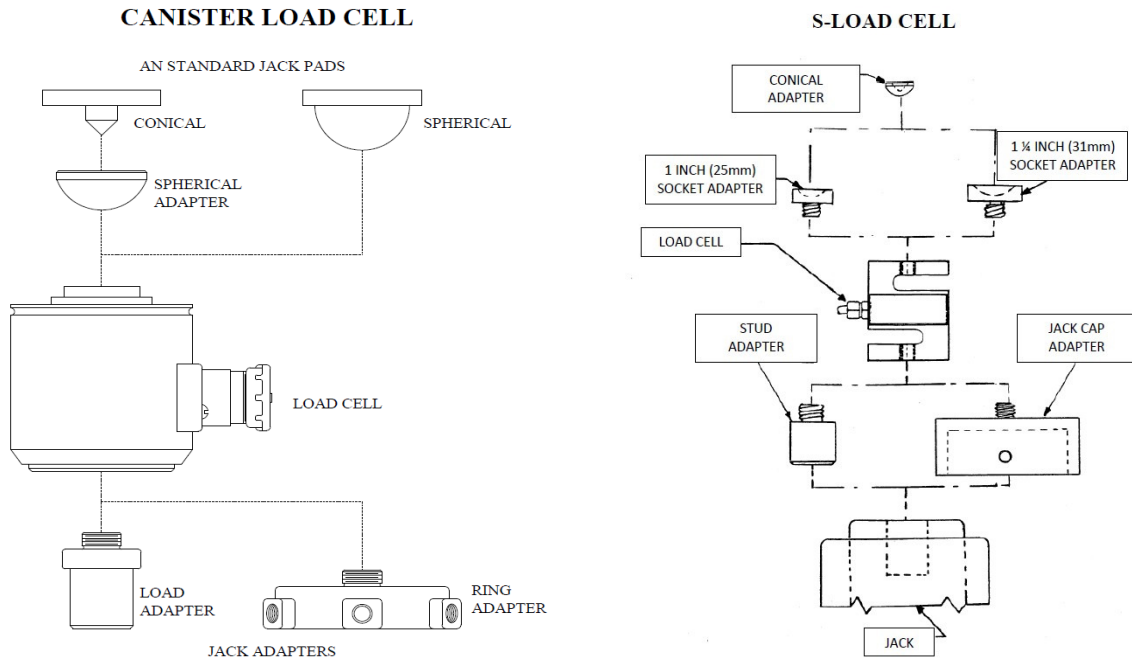

The load cells are in a kit that accompanies each EW 9150 Weighing System. Each kit contains from 3 to 5 sealed load cells. These load cells are precision devices and will withstand 150% overload without damage. Dropping a load cell, however, could damage the signal cables, the diaphragm, or other components affecting its operation or accuracy.

Each load cell has a tapped hole on the bottom to receive a plug or a ring jack adapter. The top surface has a 3/4" radius concave surface to receive either the spherical surface of an adapter or the aircraft jack pad directly.

Note:

Load Cells must always be used with their matching (color coded) spherical adapters. When changing load cell locations, ensure that the spherical adapter/load cell combination remains intact.

Load Cell Adapters

For the purpose of mounting load cells under varying physical arrangements, several adapters are provided (See figures above):

1. Plug and ring adapters for securing the cell to the hydraulic jack.
2. Spherical adapters to allow interfacing transition between the cells and conical jack pads or flat surfaces. Axle adapters are also provided which allow transition from the cell to the cylindrical surface of the axle.

COMPONENT DESCRIPTION

Aircraft Weighing System Kits.



Case dimensions and weight (typical):

Length: 31 inches
Width: 25 inches
Height: 18 inches
Typical weight: 75 to 85 lbs.

Kit Contents

- 1. EW 9150 Controller/Display.
- 2. Load cells (Cells) 3 to 5. Color coded to match cables.
- 3. Cable sets, color coded.
- 4. Load adapters, various configurations.

COMPONENT DESCRIPTION

Aircraft Weighing System Kits Available.

Each kit contains all components necessary to complete the weighing system.

- 3 to 5 load cells.
- Rugged controller display.
- Matched color coded cables.
- Power supply and power cord.
- Adapter accessory kit.
- Rugged carrying case.

AIRCRAFT WEIGHING SYSTEM SPECIFICATIONS

- Accuracy: 0.1% of applied load or 0.02% of channel capacity, whichever is greater.
- Calibration Method: Dead weight or hydraulically controlled load cell reference standards.
- Environmental: Operating temperature range: 14° F to 120° F (-10° C to 50° C).
Storage temperature range: - 4° F to 140° F (-20° C to 60° C).
IP65 for load cells.
IP65 for system components.
Relative Humidity: 95% non-condensing.
System case: rugged, impact resistant and waterproof.
Controller/Display case: rugged, impact resistant and water resistant.
- Regulatory: RoHs compliant components
- Electrical: 90-240 VAC
50 to 60 HZ
1 amp.
5 amp with printer (Optional).
- Options: Thermal tape printer.
- Features: User-friendly interface in darkness and weight readings visible in sunlight.
Bright Electronic display, visible at long distance.
3 to 5 channels, with an option for a sixth channel.
Reconfigurable load cell arrangement.
Automatic latitude and elevation compensation.
Automatic zero tracking.

SETUP/PRE-OPERATION

Pre-operational Procedures

Place the EW 9150 Kit in any convenient location within the length of the load sensor cables. Unreel the cables and connect them to the proper load cells, observing color codes; i.e., red to red, yellow to yellow, etc. It is important to insure that cables are never pinched, cut, or crushed, and that open connectors are never exposed to water, grease or other conductive material that may cause shorting of the channel excitation voltage. It is essential that site latitude and elevation be setup correctly. Refer to Setup Pre-operation, steps 6 and 7, pages 18, 19, 20.

Load Cell Jack Point Configuration

EW 9150 Weighing System accommodates jack point configurations for 3-point, 4-point (helicopter or fixed wing) and 5-point aircraft. Position of the load cells is shown in the table below.

3 Load Cells		
Channel 1	Red	Left
Channel 2	Green	Right
Channel 3	Yellow	Nose
4 Load Cells		Helicopter
Ch 1 Red	Fwd Left	Left
Ch 2 Green	Fwd Right	Right
Ch 3 Yellow	Aft Left	Nose
Ch 4 Blue	Aft Right	Spare
5 Load Cells		
Channel 1	Red	Left (1)
Channel 2	Green	Right (1)
Channel 3	Yellow	Nose
Channel 4	Blue	Left (2)
Channel 5	White	Right (2)

NOTE: It is mandatory to match the load cells and the mechanical adapters to ensure precision and consistency of weighing values.

NOTE: Color coded spherical adapters must be used with color coded load cells.

CAUTION: Use proper adapters to prevent jacks from slipping or buckling. Damage to the aircraft or inaccurate weight readings may result. Never apply load to the rim of the cell.

SETUP/PRE-OPERATION

Preparation for Aircraft Weighing

1. Review the Equipment List of the aircraft being weighed. Update the list as required. Ensure any equipment, which will normally be installed but is missing at the time of the weighing, is added in the later calculations.
2. Remove all equipment which will not be included in the above list.
3. Clean the aircraft to remove accumulated dirt, grease and trapped water.
4. Fill the oil tanks to a known quantity. Fill all reservoirs, such as anti-icing fluid, to capacity.
5. Drain fuel tanks. If draining is not practical, fill the tanks to capacity. Add or account for unusable fuel.
6. Determine the unit weight of fuel. The user shall follow all applicable safety procedures specific to local regulations and procedures. Variations in fuel weight, particularly in the case of jet aircraft, can cause appreciable difference in the final empty weight and CG determinations. Use caution for partially filled non-symmetrical fuel tanks.
7. With tricycle gear aircraft, it is often desirable to level the aircraft as closely as possible before lifting on the jacks. Changing oleo strut extensions can be helpful.
8. A stabilizing period of 10 minutes running concurrently with a warm-up period is advisable. When using jack adapters, ensure the adapter is fully threaded into the cell. Using ring adapters, ensure it is centered flush on the rim.
9. It is recommended that the load cells along with adapters be exercised prior to performing an actual weighing. Exercise the load cells 2 to 3 times by lifting the aircraft with the load cells and jacking system in place.
10. The EW 9150 has color coded cables. The identifiers for each color coded channel are clearly visible on the display. It is mandatory to conform to the color schemes as indicated on the display.

SETUP/PRE-OPERATION

Control Panel Setup

Follow these steps to configure the EW 9150 Weighing System via the control panel:

1. Connect the power cable. The AC power should connect to a 110 VAC to 240 VAC outlet. The following screen will appear (Channel values may be different than shown here):

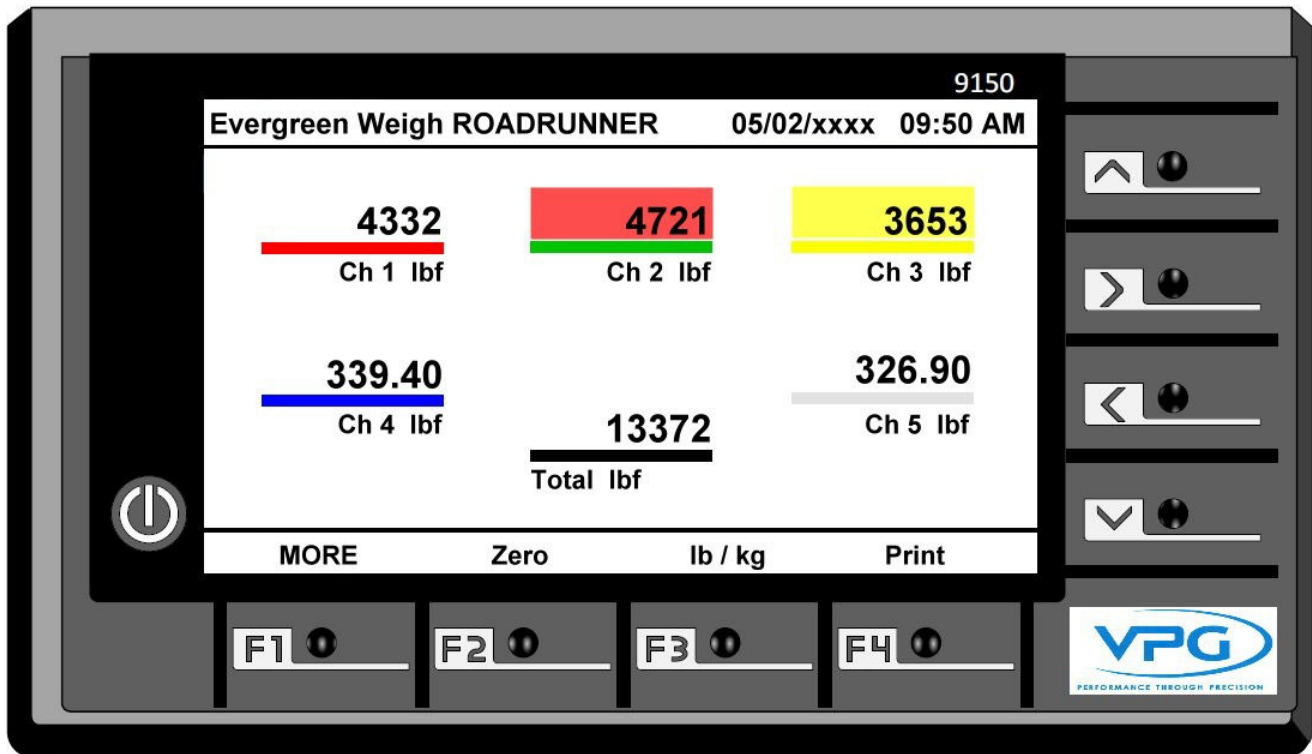

The colors indicated above each channel indicate dynamic state of force indications.

Red indicates an unstable scale.

Yellow along with an error code, indicates a channel fault. Refer to pages 26 and 27 for further explanations of error codes.

Touching the 'Zero' function button, sets no-load channel offsets to zero.

Touching 'lb/kg' changes units of force from 'lbf' to 'kgf' or vice versa.

Touching 'Print' key results in a hardcopy printout of weight record.

SETUP/PRE-OPERATION

Control Panel Setup (Contd.)

2. Press the 'More' button for setup functions. The following screen appears:

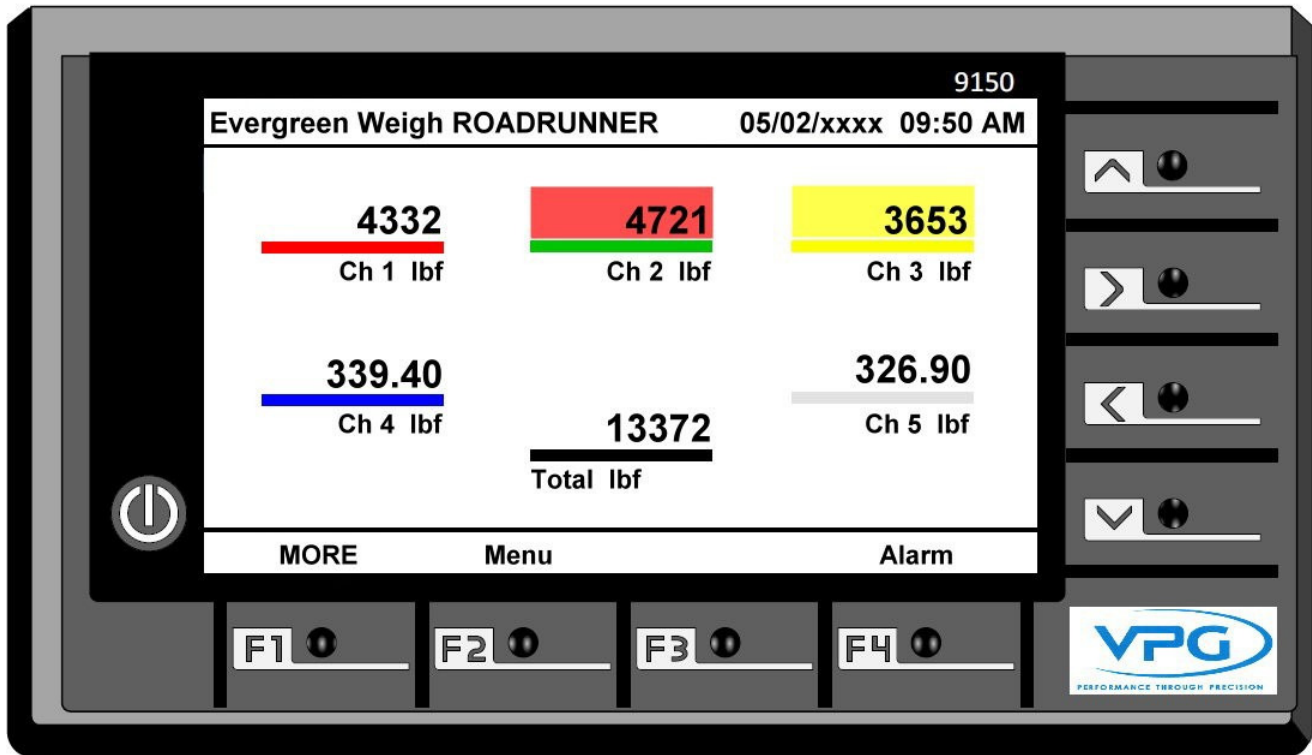

SETUP/PRE-OPERATION

Control Panel Setup (Contd.)

3. Press 'Menu' button. The following screen appears:

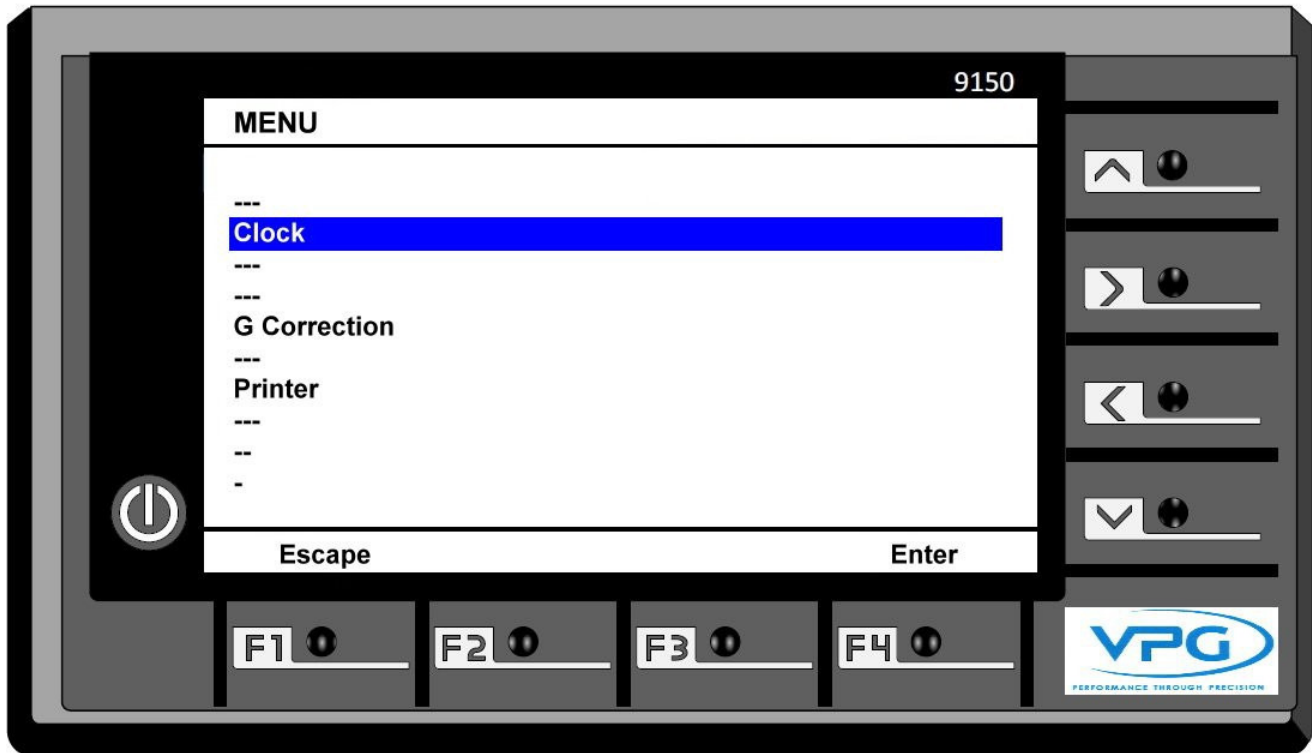

The Clock, G Correction and Printer can be accessed here.

SETUP/PRE-OPERATION

Control Panel Setup (Contd.)

- Using the down arrow, scroll down to Clock, press the 'Enter' button F4. The following screen appears:

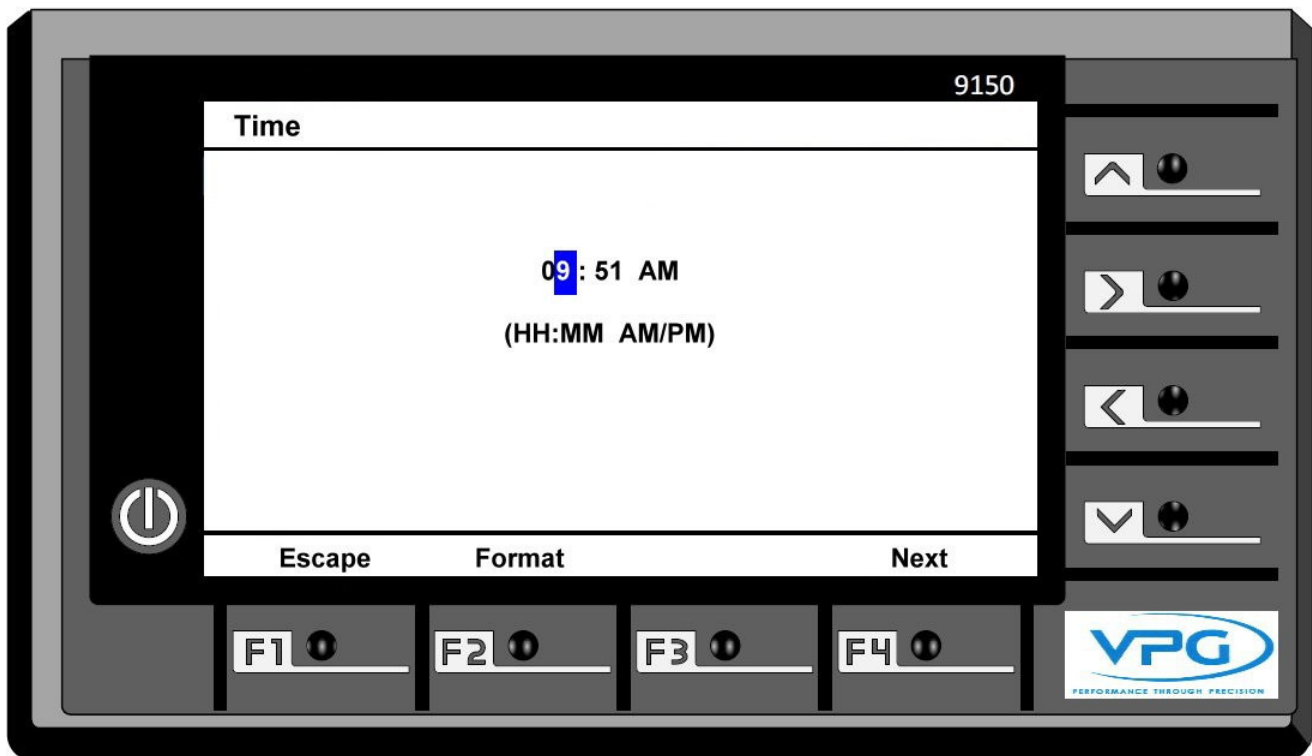

Press 'Format' to change from standard time to 24 hour time.

Using the left and right arrows, move between hours and minutes, using up and down arrows, change value desired. Change AM to PM etc.

SETUP/PRE-OPERATION

Control Panel Setup (Contd.)

5. Press 'Next' button. The following screen appears:

Using the left and right arrows, move between month and day, using up and down arrows, change to present date. Press 'Escape'. The screen will return to the power up screen.

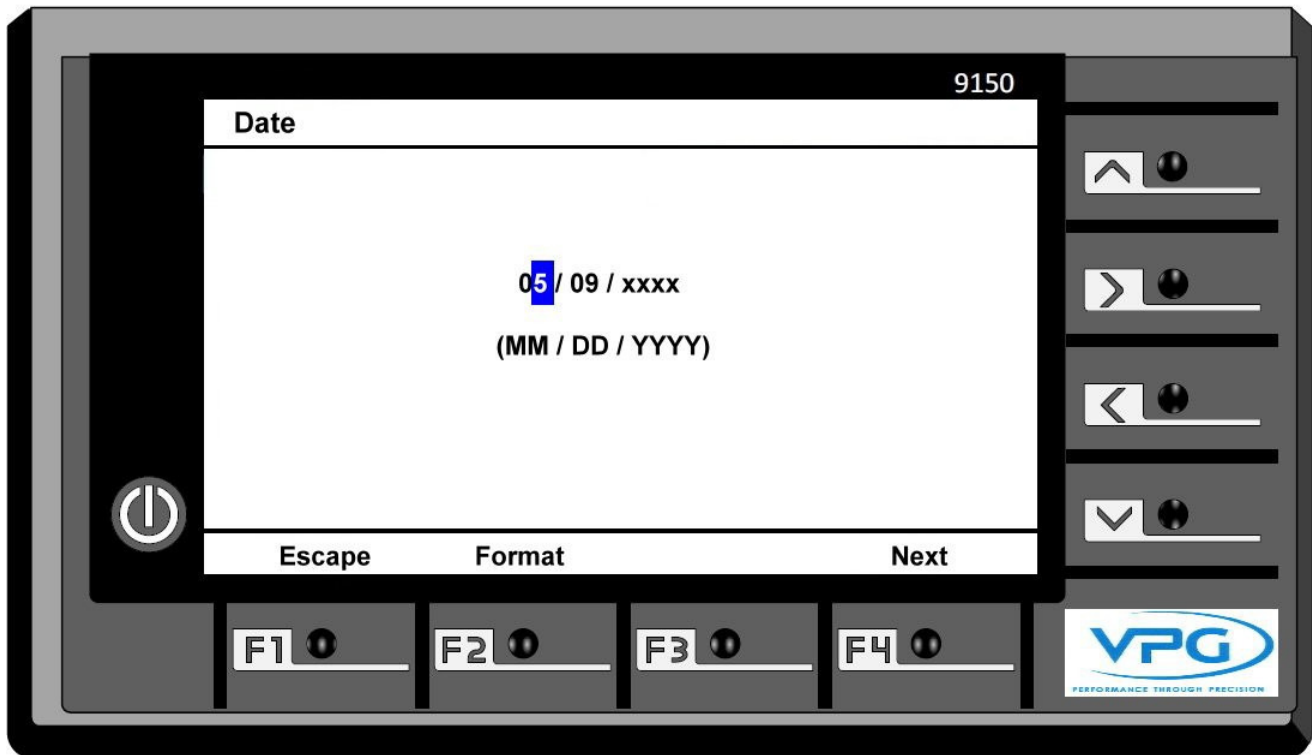

SETUP/PRE-OPERATION

Control Panel Setup (Contd.)

6. Press 'More', press 'Menu', scroll down to G Correction, press 'Enter'. The following screen will appear: Scroll up or down to Latitude (deg), press 'Enter'.

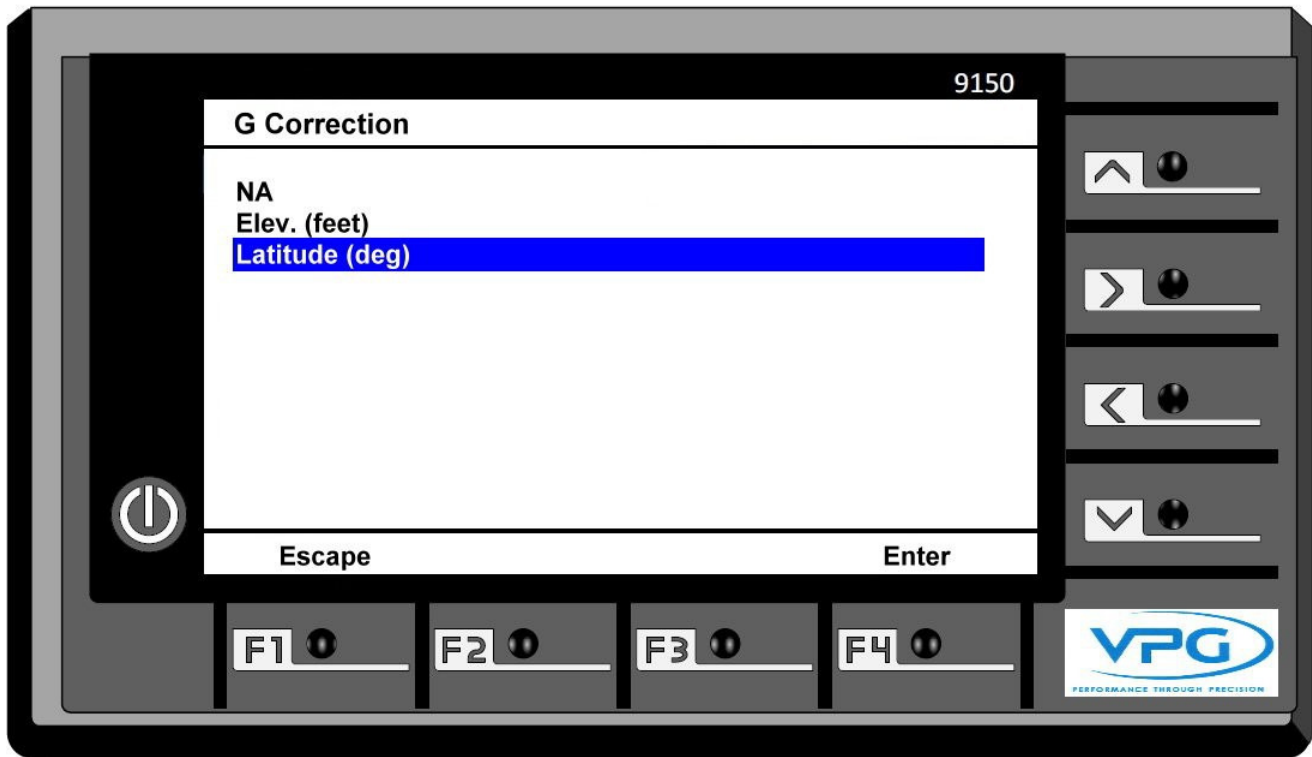

SETUP/PRE-OPERATION

Control Panel Setup (Contd.)

6. Continued...

The following screen appears:

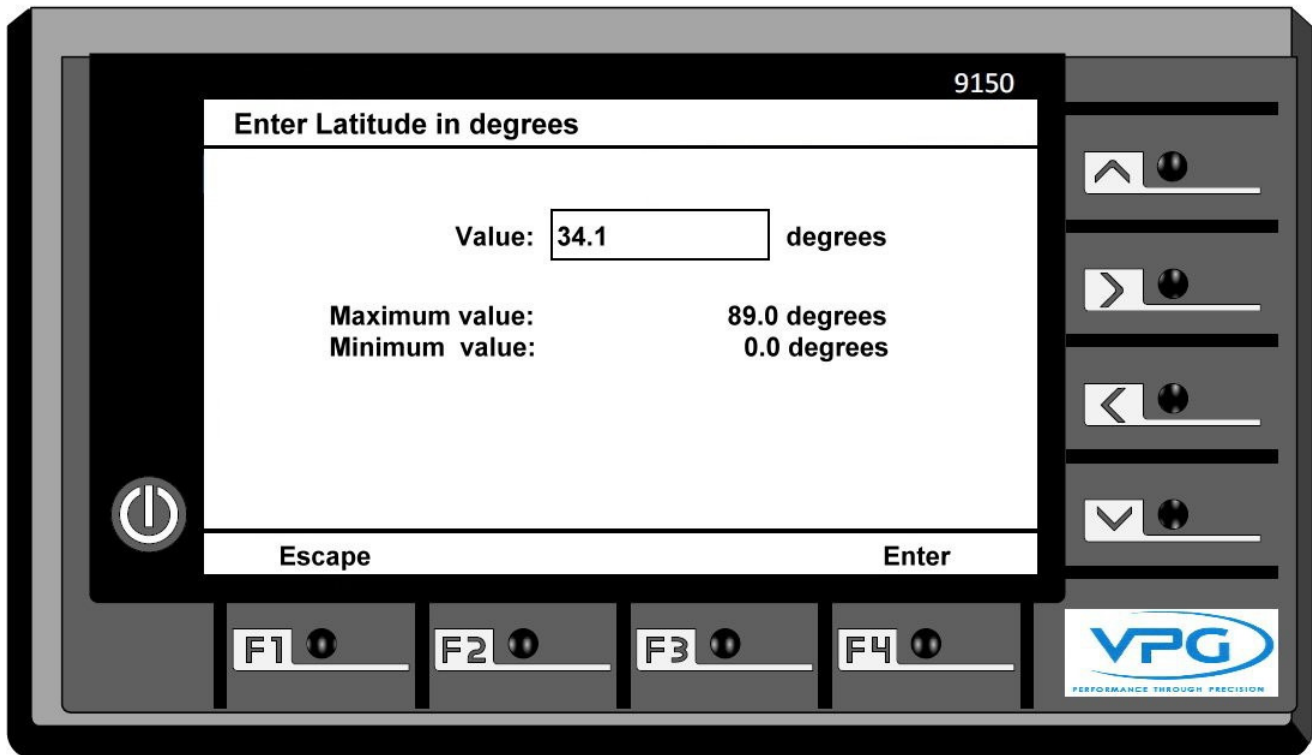

Using the up and down arrows, change value of Latitude if necessary. Use the left and right arrows to move position. If value is correct for the present location, press the 'Enter' button. Press 'Escape' to return to the main power up menu.

SETUP/PRE-OPERATION

Control Panel Setup (Contd.)

7. Press 'More', press 'Menu', scroll down to G Correction, press 'Enter'. Scroll up or down to Elev. (feet), press 'Enter'. The following screen appears:

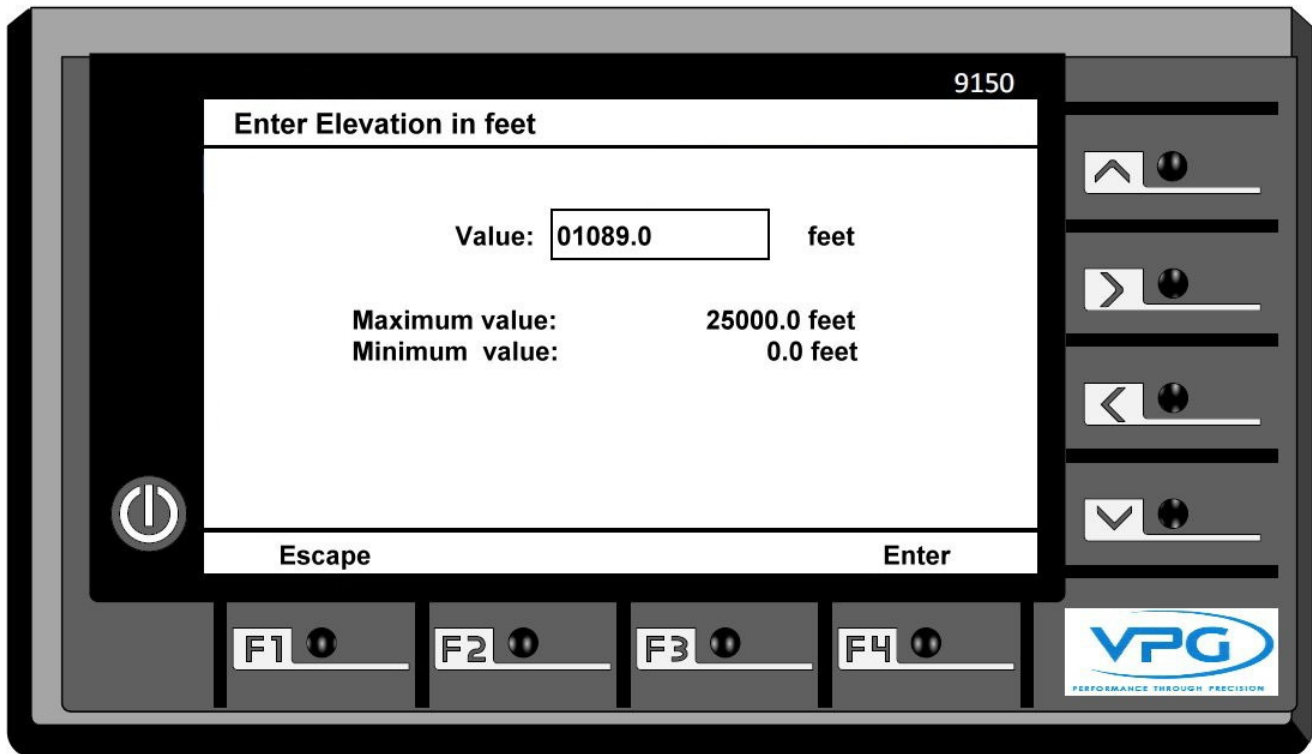

Using the up and down arrows, change value of elevation if necessary. If value is correct for the present location, press the 'Enter' button. Press 'Escape' to return to the main power up menu. End.

SETUP/PRE-OPERATION

Control Panel Setup (Contd.)

Control Panel quick setup steps from power up screen:

To Set Latitude:

1. Press 'More'.
2. Press 'Menu'.
3. Scroll to G Correction, press 'Enter'.
4. Scroll to Latitude, press 'Enter'.
5. Select values, press 'Enter', press 'Escape'.

To Set Elevation:

1. Press 'More'.
2. Press 'Menu'.
3. Scroll to G Correction, press 'Enter'.
4. Scroll to Elevation, press 'Enter'.
5. Select values, press 'Enter', press 'Escape'.

To Set Time and Date

1. Press 'More'.
2. Press 'Menu'.
3. Scroll to 'Clock', press 'Enter'.
4. Select correct time using up and down, left and right arrows, press 'Next' set date.
5. Select values for date, press 'Escape' when done.

OPERATION

Load Cell/Jack placement

Place load cell equipped jacks in position beneath aircraft jack points as shown. Ensure that the load cell cables are routed so that they will not be crushed or pinched when the aircraft is raised or lowered. Connect the cables to their color coded receptacles at the cable connection ports on the EW 9150.



Apply power to the EW 9150 and observe the initial power up screen:

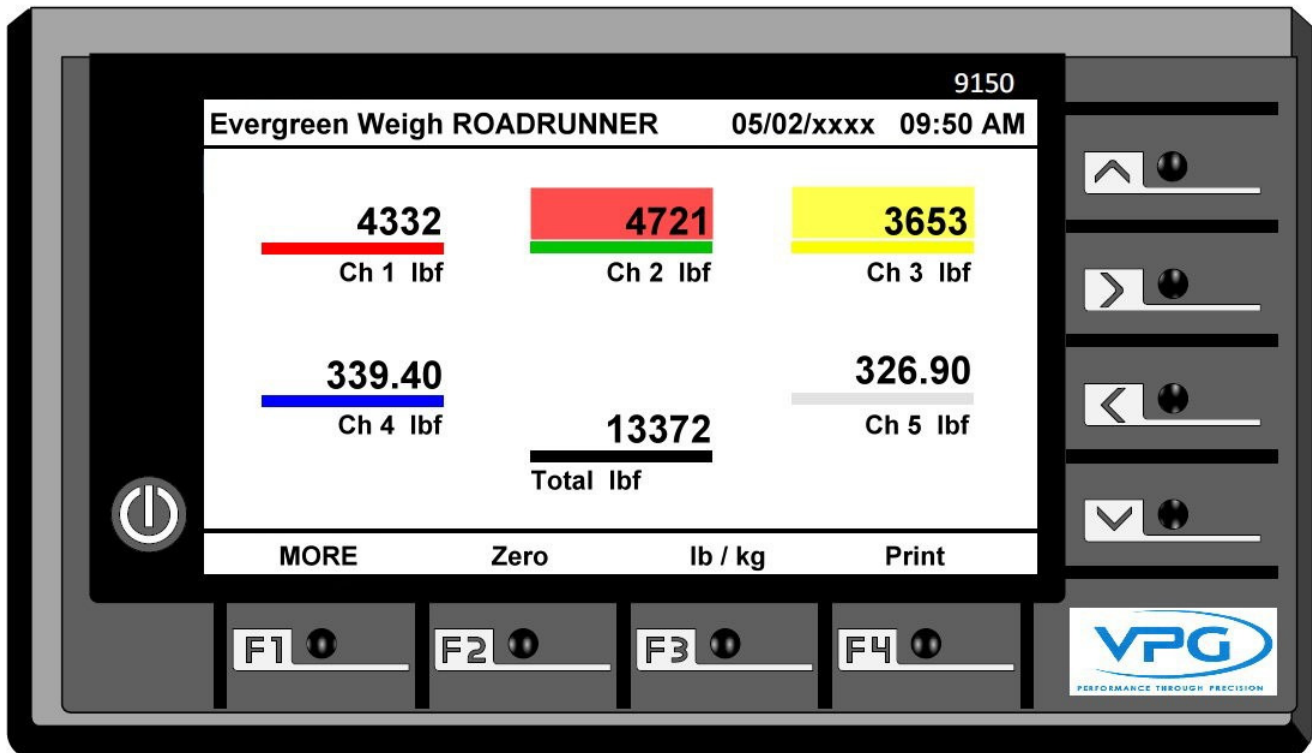

Verify that the number of channels displayed are consistent with your requirements. If not, call Factory immediately. If Red or Yellow appears, channel is not stable or an error condition exists. See trouble shooting section. Press Zero button to remove no-load offsets.

OPERATION

Aircraft Weighing Cycle

Prior to weighing, VPG recommends that the aircraft be raised and lowered 2 or 3 times ('dry runs') to acclimate system load cells. Actual weighing is accomplished in five steps: Zeroing, Lifting, Weighing, Removing and Reporting. Each step must be performed sequentially and successfully before proceeding to the next step.

Zeroing

Under ideal conditions, with the EW 9150 powered up and in a no load condition (no jack contact with aircraft jack points) the reading for each channel should be zero. However, in reality, it is often necessary to "zero out" minor variances in any or all of the system cells. Touch the 'ZERO' button to zero all cells simultaneously.

Lifting

The aircraft must be jacked up so that it is resting exclusively on the load cell based jacks. Jacking should be done in accordance with aircraft manufacturer specifications, if provided. During the jacking or lifting phase, wheel weight values will appear with a red channel background indicating that weight is unstable. When jacking is complete, the red background on the channel will disappear (stable state) and weight readings for the cell should appear as normal for the channel.

Weighing

When the aircraft is fully jacked up, shown below, readings are stable (no red bar weight indicators) press the PRINT button. This will accurately record the weights and settings in the printout.



OPERATION

Weighing (Contd.)

NOTE: The operator must be satisfied that the weighing is valid and stable. Operator acceptance also considers factors such as the aircraft is completely clear of the ground (floor) and all items aboard are considered necessary for weighing. The fully jacked aircraft may not enter a “stable” condition regardless of the amount of load applied. The operator is free to change the loading or simply wait until a final weight stabilization reading is achieved on the display (with no data changing red bars showing). Any outside force, wind on control surfaces, vibration, etc., may keep the system from reaching a “stable” condition. It is important for the operator to exercise good judgment at this point.

Removing

Removing is the reverse of lifting. At this time, lower the aircraft to its original resting position and ensure there is no contact between the load cells and the jack points. The channel readings on the EW 9150 should return to the no-load state. Review any/all error messages and the data printout to decide if the weighing can be accepted or the aircraft must be re-weighed.

Reporting

The printout sheet is the document to be used for actual and accepted weighing. Ensure the readings are legible and that any error condition is noted. If the printout data is acceptable and the aircraft is not being weighed again, remove all jacks, hardware, cables and return to their storage position in the kit.

OPERATION

Printer Format (Printout)

Evergreen Weigh ROADRUNNER

MM/DD/YYYY 12:25 PM

Gravity Correction

User Site Elevation (ft): 1089

User Site Latitude (deg): 34.1

Gravity Correction: 0.999999

Force Unit 'lbf'

(Red) Channel No: 1

Stable

Net Force Value: 4333

(Green) Channel No: 2

Stable

Net Force Value: 4721

(Yellow) Channel No: 3

Stable

Net Force Value: 3653

(Blue) Channel No: 4

Stable

Net Force Value: 339.25

(White) Channel No: 5

Stable

Net Force Value: 327.05

Total Force: 13373

TROUBLESHOOTING

Troubleshooting and Error Codes

In case of a malfunction, it is recommended to perform a thorough visual inspection of the load cells, cables, bulkhead connectors, power cables, etc. Often a visual inspection alone reveals the source of the problem. Customer support can then be called upon to send replacements for damaged parts. The system will display a diagnostic number indicating an abnormality resulting from faulty components. Many error codes are internal to the controller/display and cannot be corrected externally in which case the unit must be returned to the factory for repair. The table below shows the error codes:

Code	Definition
0	No Error
3	Instrument is not in a normal state. Internal fault.

Weight Input Errors

Code	Definition
5	AD Converter over range.
7	AD Converter under range.
10	Excitation voltage error.
X	The weight channel is not in use.
16	No valid data available.
17	Channel weight calculation error. Internal memory error.
18	Channel weight out of range. (Faulty calibration, faulty configuration data).
20	High current error. Short circuited load cell cable.
21	Low current error. Load cell signal cable break.
23	Waiting for valid weight. CAN bus error.
24	Low ADS12585 Supply. Power supply fault.

TROUBLESHOOTING

Troubleshooting and Error Codes (Contd.)

General command/communication errors

Code	Definition
101	Value above high limit. Internal memory fault. Call factory.
102	Value below low limit. Internal memory fault. Call factory.
103	Illegal value error. (All other value errors)
104	Choice is removed.
105	Change of setup parameter not allowed.
106	Illegal setup index.
107	Calculated weight gradient illegal. Memory error. Call factory.
108	Illegal number of bytes in a CAN message. (No error text) Restart.
109	Illegal start-up CAN command. (No error text)
110	The instrument is NOT in production mode.
111	Any CAN communication error.

Hardware errors

Code	Definition
200	EEPROM error. Restart. If error persists, call factory.
201	Writing to ICU EEPROM error. Internal memory error. Call factory.
202	Acceleration error.
203	Error 12C Port
204	A-port ID-detect (output) error.
255	Default error, undefined.

MAINTENANCE

Maintenance

Equipment should be kept free of dirt and grease. Dust caps should be kept on the electrical receptacles of the load cells when not in use.

Only routine maintenance is recommended on the aircraft weighing kits. It is recommended that the kits be returned to the factory on an annual basis (or sooner) for calibration and re-certification if trouble is observed or erroneous readings are suspected.

All equipment needing to be returned to our facilities in either the United States or Europe will require a Return Material Authorization number (RMA) to be issued prior to returning. The equipment must have the issued RMA number boldly displayed on the exterior of the packaging.

Please phone 301.722.6000 to obtain an RMA number prior to shipping.

The equipment must be received within 30 days of issuance of the RMA to be valid.

WARRANTY

Revere/Evergreen Weigh

1. Platforms, Load Cells and Indicator shall be free of defects in materials or workmanship for one year after delivery.
2. Cables are warranted to be free from defects in workmanship or materials for ninety (90) days after delivery.

This warranty may be considered as unconditional provided that, the equipment has not been mechanically, electrically or environmentally abused. This determination to be undertaken by personnel from Revere/Evergreen Weigh.

Structural damage caused by insufficient support of the weighing platform is not covered under the warranty.

Warranty repairs must be performed at the factory. Repairs performed by any other individual or agency will not be warranted by Revere/Evergreen Weigh against later failures.

This warranty is limited, at the option of Revere/Evergreen Weigh to repair, replacement or an appropriate credit adjustment not to exceed the original sale price paid to Revere/Evergreen Weigh.

Revere/Evergreen Weigh assumes no liability in connection with the sale or use of the scale beyond that stated above.

Limitation

Since troubleshooting of possible scale problems is designed for simplicity, the user is expected to perform basic performance checks and contact Revere/Evergreen Weigh service if questions arise.

This policy is consistent with elimination of unnecessary expenses and is reflected in reduced prices for our products.

APPENDIX

I Dummy Plug

Introduction

Customers, who need to use an Aircraft Weighing system set up as a four or five Load Cell system, may sometimes select to use merely three Load Cells for perhaps weighing a lighter aircraft. The current system set up is designed to display a fault if the required number of Load Cells is not the same as prescribed at the time of order placement.

A dummy plug is a device which simulates a non-deflecting Load Cell. Thus, a four Load Cell system may be employed to work as a three Load Cell system with a “dummy” plug inserted into the fourth channel. The EW9150 is led to believe that a totality of four Load Cells is still connected despite the fact that only three Load Cells are active. No fault indications are generated. The dummy plug will always generate a force signal of zero (provided that the system is set to zero with no loading), and therefore, will not in any manner whatsoever, impact on the Total Force readings.

User

The dummy plug is designed to interface to any of the channel inputs. We do not recommend that more than one dummy plug be used at any one time.



Dummy Plug

**Revere/Evergreen Weigh
Vishay Precision Group**

Technical Support: (253) 872-1910